

LC-D0515 LED

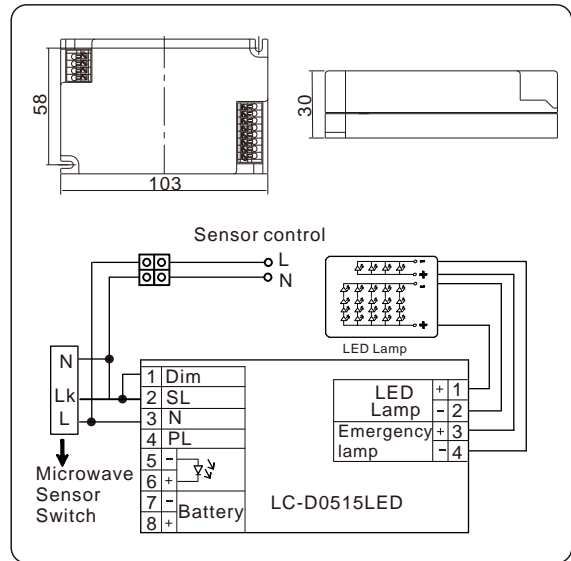
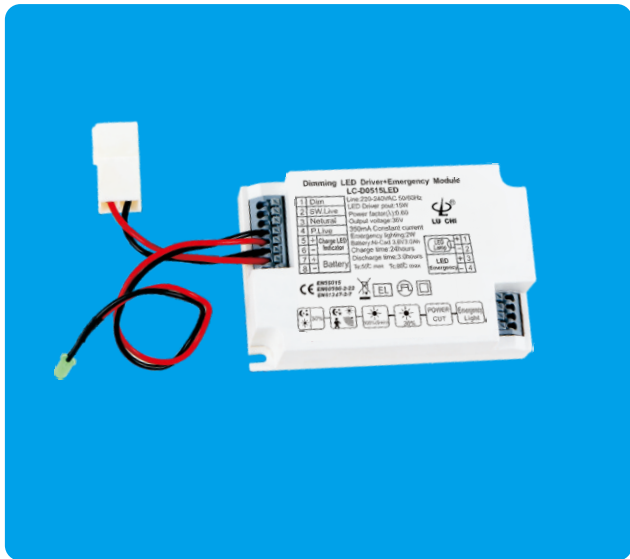

SPECIFICATION/DESCRIPTION:

LED driver and Emergency power combined , configured with 18-48V LED module, suitable for different lights provide battery charge and discharge, with DALI-2 control function or individual auto-test function.

APPLICATION RANGE : downlight, panel light, ceiling light etc.

WORKING VOLTAGE: 220-240VAC 50-60Hz **OUTPUT VOLTAGE:** 18-40V

POWER FACTOR: 0.95 **WORKING CURRENT:** 350mA

EMERGENCY POWER: 2.5-5W **OUTPUT MODE:** constant power output

AMBIENT TEMPERATURE: 0...55°C **WARRANTY:** 3Years

FUNCTION:

Aisle light +emergency lighting module
 Can work with microwave sensor to implement dimming and rated constant light function
 Brightness can be adjusted as ambient changed, but the light can't be turned off
 Constant light 30%, 100% brightness when sense it

STANDARD

EN 60598-1, EN 60598-2-22, EN60598-2-1, EN61347-1, EN61347-2-7, EN61347-2-13, EN62031, EN62471, EN61000-3-2, EN61000-3-3, EN55015, EN61547, IEC TR62778,

DALI-2 protocol: 101 102 202 104 251 252 253 254 207

Certificate: CE, EMC

LC-D0515 LED Series

Type No	Input	DC Output	Battery	Power	Function	Qty	Weight	Packing
60003000	220-240V	20-42V	LiFePO4 6.4V/1.5AH	2.5W	Autotest	20pcs	5Kgs	24X22X16CM
60003001	220-240V	20-42V	LiFePO4 6.4V/3.0AH	5.0W	Autotest	20pcs	6Kgs	24X22X16CM
60013000	220-240V	20-42V	LiFePO4 6.4V/1.5AH	2.5W	DALI-2	20pcs	5Kgs	24X22X16CM
60013001	220-240V	20-42V	LiFePO4 6.4V/3.0AH	5.0W	DALI-2	20pcs	6Kgs	24X22X16CM