

## LC-LA0105LED

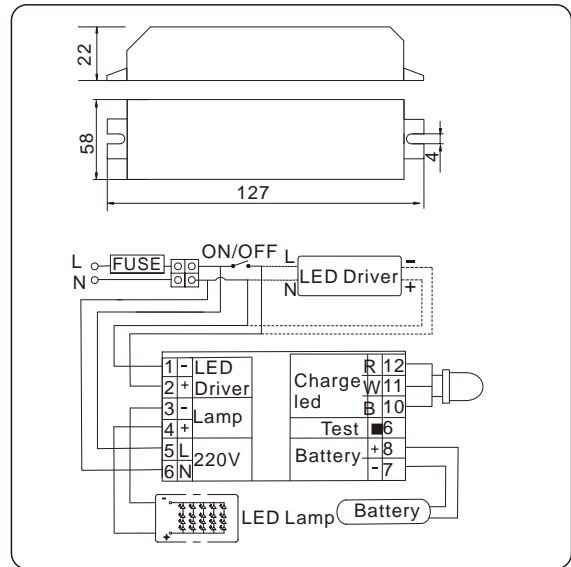

### SPECIFICATION/DESCRIPTION:

LED Emergency Converter: non-maintained working mode, suitable for different lights with external driver, provide battery charge and discharge.

**APPLICATION RANGE :** downlight, tri-proof light, ceiling light, panel light...etc.

**WORKING VOLTAGE:** 220-240VAC 50-60Hz

**OUTPUT VOLTAGE:** 12-200V

**DISCHARGE CURRENT:** 550-1200mA

**OUTPUT MODE:** inverter mode

**AMBIENT TEMPERATURETA:** 0...45°C

**WARRANTY:** 3Years

### PROTECTION FUNCTION:

- Deep discharge protection
- Short -circuit- proof battery connection
- Open-circuit -proof
- Polarity reversal protection for battery
- Fault indication
- Dual management system for battery

### STANDARD

EN 60598-1, EN 60598-2-22, EN60598-2-1, EN61347-1, EN61347-2-7, EN61347-2-13, EN62031, EN62471, EN61000-3-2, EN61000-3-3, EN55015, EN61547, IEC TR62778,

**Certificate:** CE, EMC

### LC-LA0105LED

Type No	Input	DC Output	Battery	Power	Duration	Qty	Weight	Packing
20002100	220-240V	12-200V	Li-ion 3.7V/2.2AH	2-4W	1.5H	50pcs	9Kgs	43X27X22CM
20012100	120-277V	12-200V	Li-ion 3.7V/2.2AH	2-4W	1.5H	50pcs	9Kgs	43X27X22CM